

CHEMUNG COUNTY - CITY OF ELMIRA

PURCHASING DEPARTMENT

John H. Hazlett Building – 2nd Floor

203 Lake Street P.O. Box 588

Elmira, NY 14902-0588

PH: 607-737-3577 FAX: 607-737-2073

Sealed Bids will be received at the CHEMUNG COUNTY - CITY OF ELMIRA PURCHASING DEPARTMENT, John H. Hazlett Building – 2nd Floor, 203 Lake Street, P.O. Box 588, Elmira, NY 14902-0588 until **Wednesday, April 15, 2020 at 1:45 PM**. The bids will then be publicly opened and read aloud in the Purchasing Department at 2:00 PM. BIDS SHALL BE SUBMITTED IN A SEALED ENVELOPE ENTITLED:

RFB-230 Clemens Square

EACH BID SHALL BE ACCOMPANIED BY A DEPOSIT IN THE AMOUNT OF: **Five Percent (5%) of the Total Gross Sum Bid** in the form of a Bid Bond. Cash will not be accepted as a deposit. Bid deposits of all unsuccessful bidders shall be returned promptly upon execution of the contract with the successful bidder.

Documents may be obtained on or after **Tuesday, March 17 2020** on line at www.empirestatebidsystem.com. Vendors must first register for either the free service or the paid service at that site. The paid service **is not required** to obtain our bids. After registration, click on *Chemung County/City of Elmira* from the list of participating agencies; click on the *title of the bid* or search the NIGP codes. Copies from any other source are not considered official copies. Only those proposers who obtain bidding documents from the Empire State Purchasing Group are guaranteed to receive addendum information, if such information is issued. PLEASE NOTE THAT IT IS THE BIDDER'S RESPONSIBILITY TO OBTAIN ALL BID DOCUMENTS (INCLUDING ADDENDA) ON THE EMPIRE STATE PURCHASING GROUP WEBSITE. IF YOU CHOOSE THE FREE SUBSCRIPTION, YOU MUST VISIT THE WEBSITE UP UNTIL THE RESPONSE DEADLINE FOR ANY ADDENDA.

PLEASE TAKE NOTICE:

The Purchasing Department is closed between the hours 12:00 Noon to 1:00 P.M.,
The Purchasing Department receives one (1) mail delivery daily after 2:00 P.M.
Bids must be received **in the Purchasing Department** by 1:45 on the due date.
Faxed or Electronic Bids will not be considered.

Technical questions regarding the plans and specifications may be directed to:

Christopher J. Bond, PE
Hunt Engineers, Architects, Land Surveyors & Landscape Architect DPC
Airport Corporate Park, 100 Hunt Center
Horseheads, NY 14845
PH. 607-358-1000
FX. 607-358-1800

Attention of Bidders is particularly called to the requirement that employees and applicants for employment are not discriminated against because of the individual's age, race, creed, color, national origin, sexual orientation, military status, sex, disability, predisposing genetic characteristics, marital status or domestic violence victim status. This project has a 5% DBE participation requirement; we also encourage W-MBE participation.

Each bidder submitting a Bid to the Owner shall execute and attach thereto, the Certification regarding Equal Employment Opportunity. Although the Bidder is not required to attach such Certification by proposed sub-

contractors to his Bid, the Bidder is here advised of this requirement so that appropriate action can be taken to prevent subsequent delay in sub-contract awards.

Also, be advised that Statement of Compliance with Section 3, Housing and Urban Development Act of 1968 is now mandatory with new procedure regarding Equal Opportunity (11246) in bid condition areas.

The City reserves the right to reject any or all bids.

CITY OF ELMIRA, NY

By: _____
P. Michael Collins Date
City Manager

Inserted in Star Gazette: **Tuesday, March 31, 2020**

25. SEPARATE CONTRACTS

- 25.1 The OWNER reserves the right to let other contracts in connection with the PROJECT. The CONTRACTOR shall afford other CONTRACTORS reasonable opportunity for the introduction and storage of their materials and the execution of their WORK, and shall properly connect and coordinate his WORK with theirs. If the proper execution or results of any part of the CONTRACTOR'S WORK depends upon the WORK of any other CONTRACTOR, the CONTRACTOR shall inspect and promptly report to the ENGINEER any defects in such WORK that render it unsuitable for such proper execution and results.
- 25.2 The OWNER may perform additional WORK related to the PROJECT by himself, or he may let other contracts containing provisions similar to these. The CONTRACTOR will afford the other CONTRACTORS who are parties to such Contracts (or the OWNER, if he is performing the additional WORK himself), reasonable opportunity for the introduction and storage of materials and equipment and the execution of WORK, and shall properly connect and coordinate his WORK with theirs.
- 25.3 If the performance of additional WORK by other CONTRACTORS or the OWNER is not noted in the CONTRACT DOCUMENTS prior to the execution of the CONTRACT, written notice thereof shall be given to the CONTRACTOR prior to starting any such additional WORK. If the CONTRACTOR believes that the performance of such additional WORK by the OWNER or others involves him in additional expense or entitles him to an extension of the CONTRACT TIME, he may make a claim therefore as provided in Sections 14 and 15.

26. SUBCONTRACTING

- 26.1 The CONTRACTOR may utilize the services of specialty SUBCONTRACTORS on those parts of the WORK which, under normal contracting practices, are performed by specialty SUBCONTRACTORS.
- 26.2 ~~The CONTRACTOR shall not award WORK to SUBCONTRACTOR(S), in excess of fifty percent (50%) of the CONTRACT PRICE, without prior written approval of the OWNER.~~
- 26.3 The CONTRACTOR shall be fully responsible to the OWNER for the acts and omissions of his SUBCONTRACTORS, and of persons either directly or indirectly employed by them, as he is for the acts and omissions of persons directly employed by him.
- 26.4 The CONTRACTOR shall cause appropriate provisions to be inserted in all subcontracts relative to the WORK to bind SUBCONTRACTORS to the CONTRACTOR by the terms of the CONTRACT DOCUMENTS insofar as applicable to the WORK of SUBCONTRACTORS and to give the CONTRACTOR the same power as regards terminating any subcontract that the OWNER may exercise over the CONTRACTOR under any provision of the CONTRACT DOCUMENTS.
- 26.5 Nothing contained in this CONTRACT shall create any contractual relation between any SUBCONTRACTOR and the OWNER.

27. ENGINEER'S AUTHORITY

- 27.1 The ENGINEER, when requested by the OWNER, shall act as the OWNER's representative during the construction period. He shall decide questions which may arise as to quality and acceptability of materials furnished and WORK performed. He shall interpret the intent of the CONTRACT DOCUMENTS in a fair and unbiased manner. The ENGINEER will make visits to the site and determine if the WORK is proceeding in accordance with the CONTRACT DOCUMENTS.

DRAWN BY : JWJ
 CHECKED BY : JCP
 DATE : 03/17/2020
 SCALE : AS NOTED

BY :
 # DATE: 3/30/20
 DESCRIPTION OF REVISION: 1
 1-2-3-4-5-6-7

Unauthorized Alterations: In Addition To Plans Being A Licensed Engineer & Architect, No Alterations Or Corrections Shall Be Made Without The Written Consent Of The New York State Education Dept.

WHITHAM
 PLANNING & DESIGN, LLC
HUNT ELAIS
 100 Hunt Center, Horseheads, New York 14845
 P: 607-538-1000 F: 607-538-1800
 Offices: Rochester, Horseheads, Tonawanda

SITE DETAILS
CLEMENS SQUARE REDEVELOPMENT
CITY OF ELMIRA
 CITY OF ELMIRA, CHEMUNG COUNTY, NEW YORK

L6.2
 PROJECT NO: 1546-106

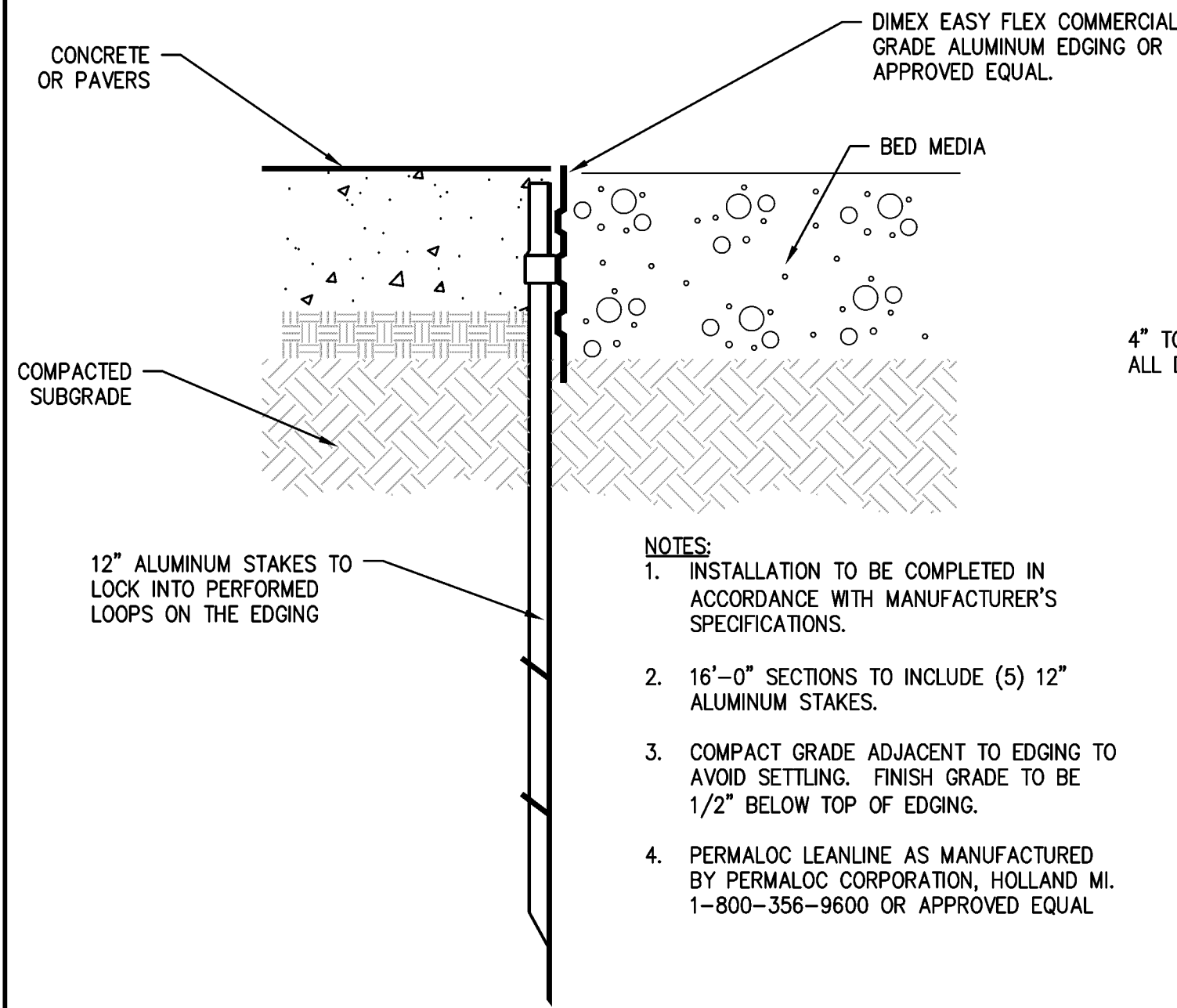

3 ALUMINUM EDGING DETAIL
 SCALE: N.T.S.

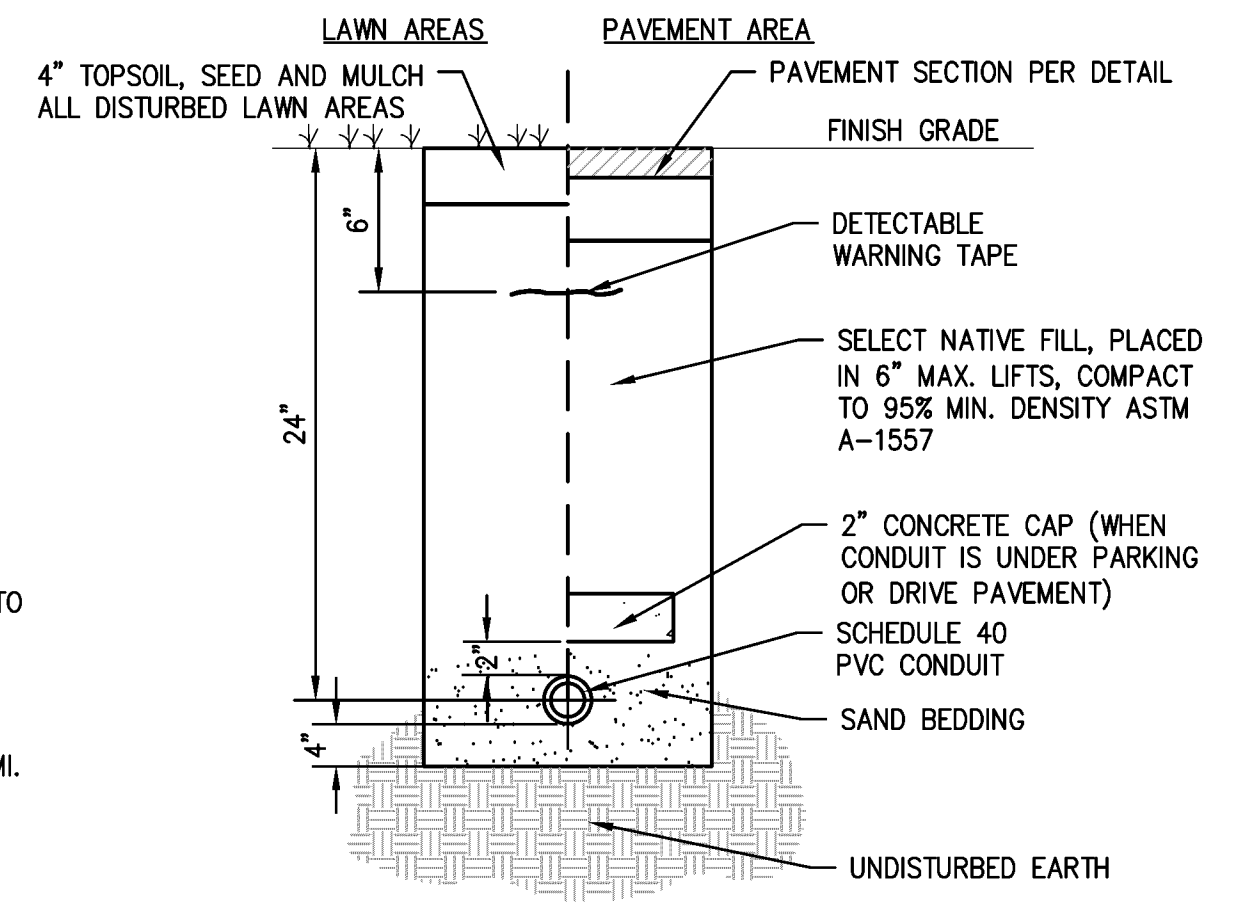

2 ELECTRIC CONDUIT TRENCH DETAIL
 SCALE: N.T.S.

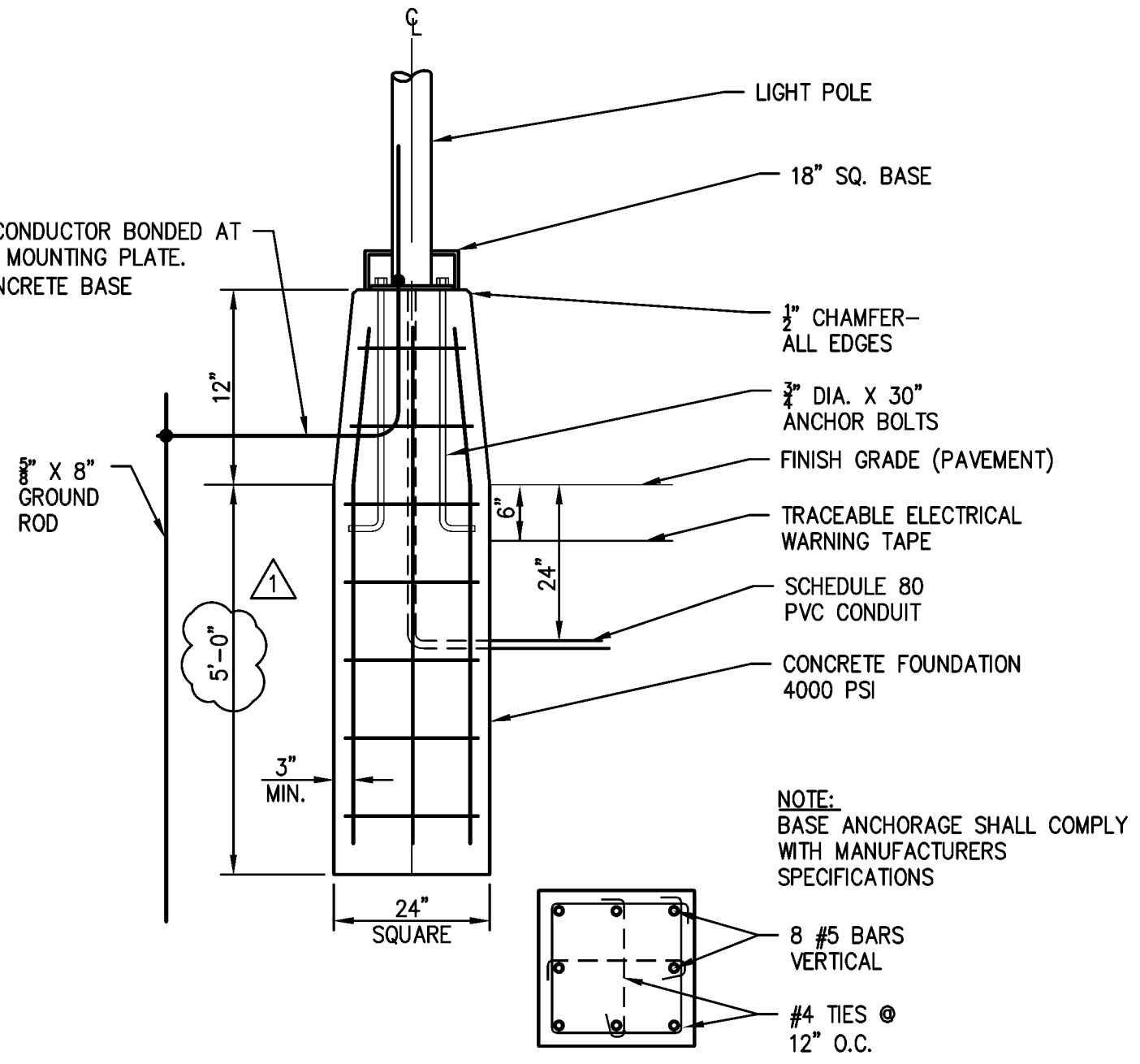

5 RAISED LIGHT POLE FOUNDATION DETAIL
 SCALE: N.T.S.

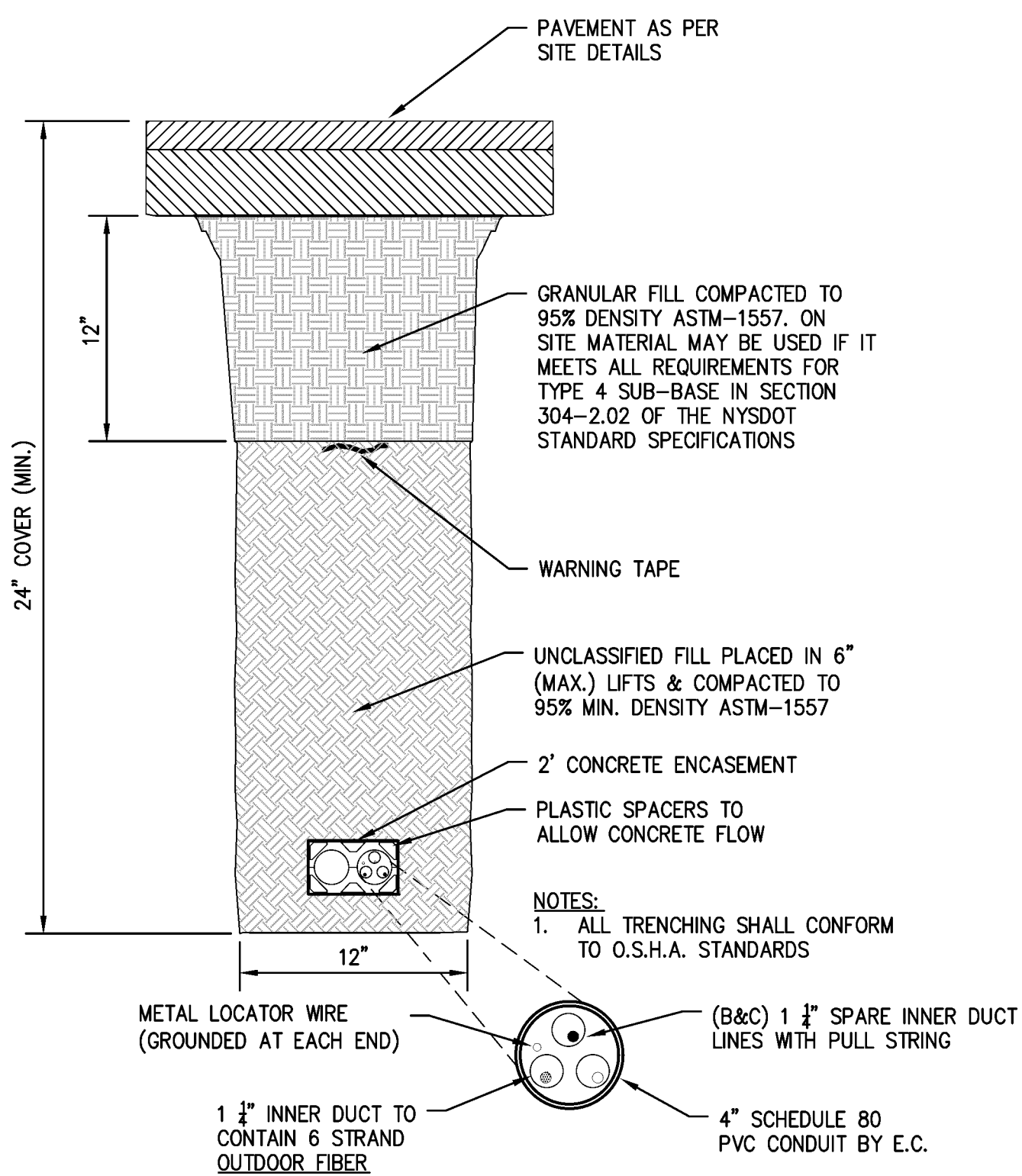

1 PULLBOX DETAIL
 SCALE: N.T.S.

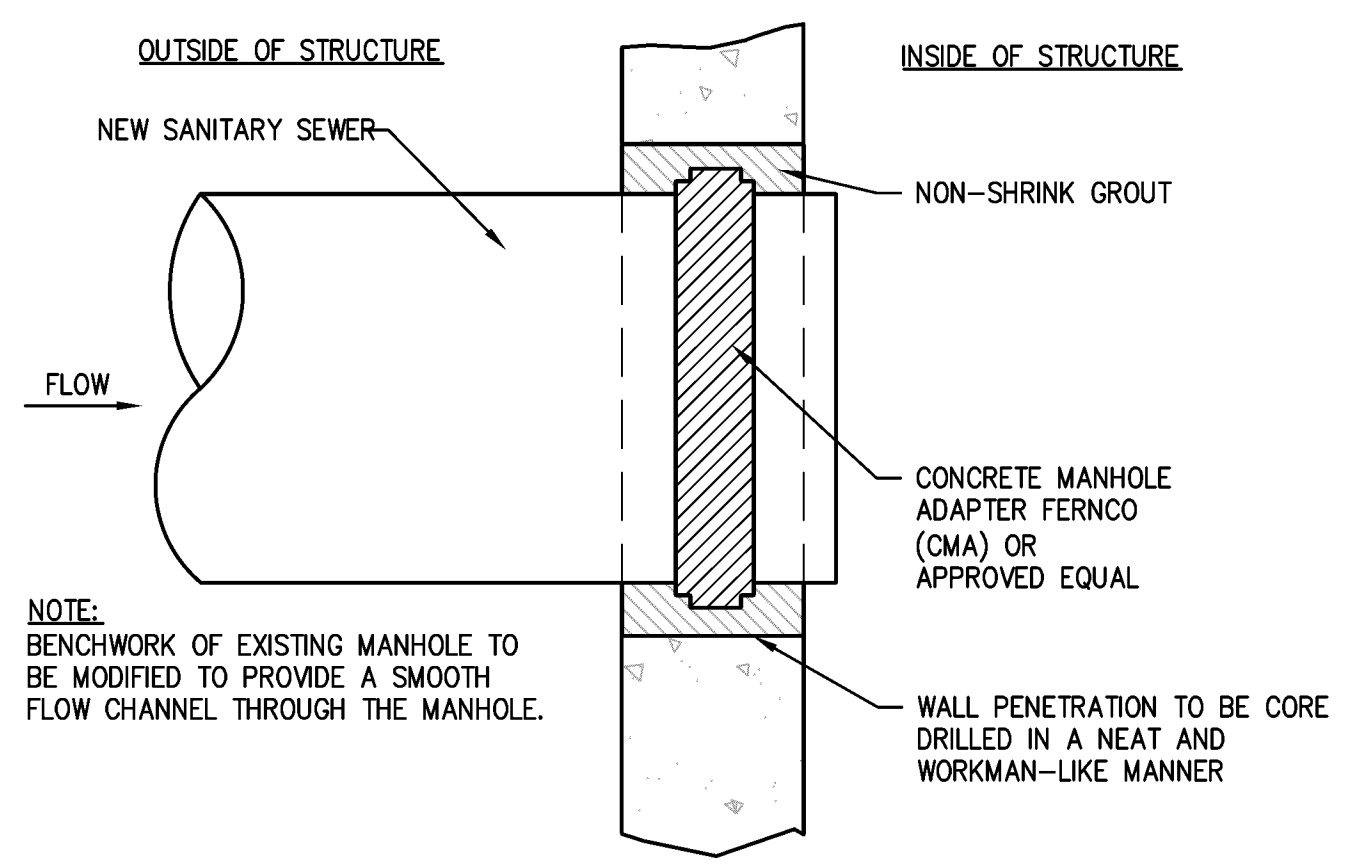

4 EXISTING STORM STRUCTURE CONNECTION DETAIL
 SCALE: N.T.S.

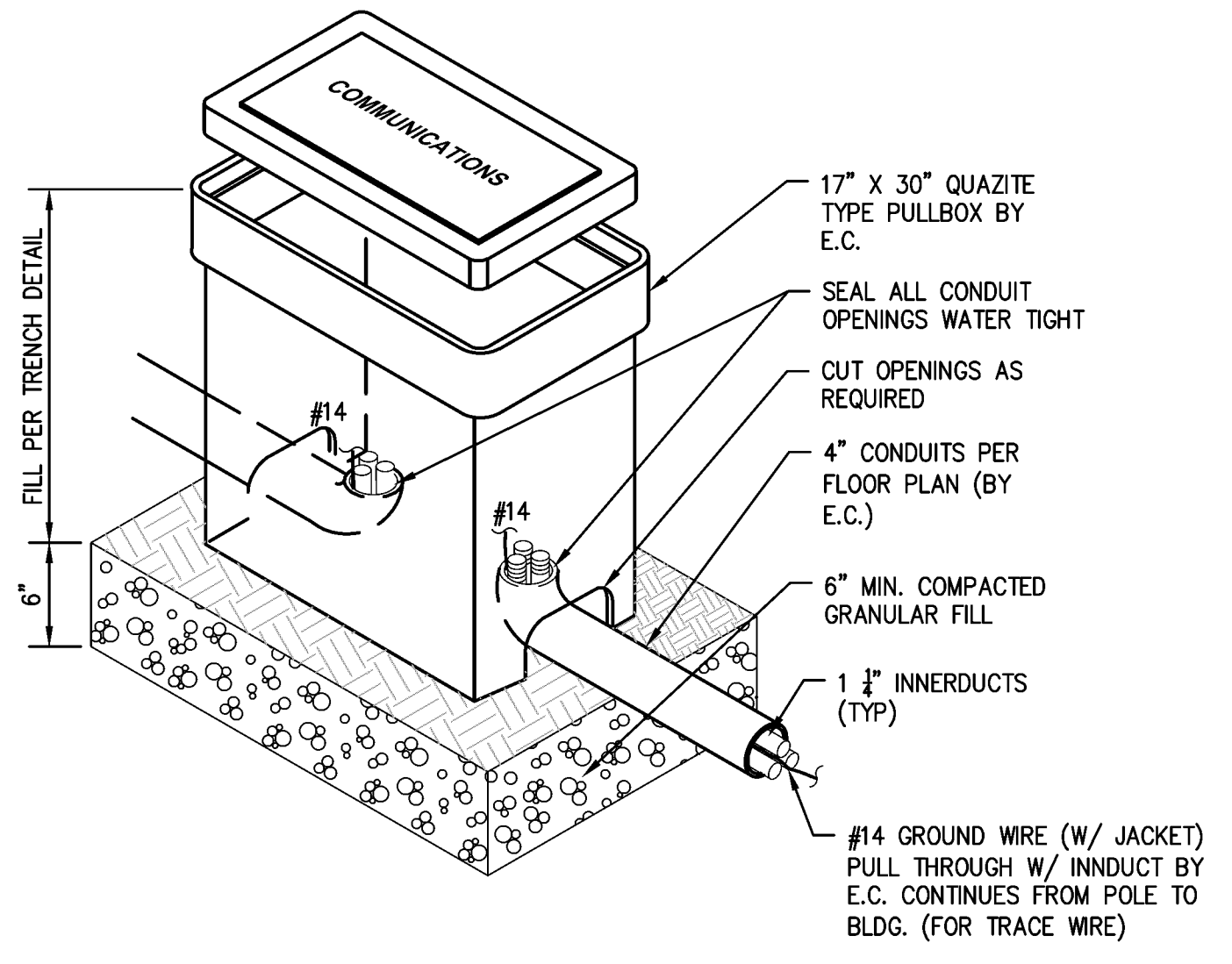

1 PULLBOX DETAIL
 SCALE: N.T.S.